

**JUKI®**

# MS-3580 Series

Feed-off-the-arm, 3-needle Double Chainstitch Machine



MS-3580SF1SN

# MS-3580 Series

This machine demonstrates increased feed efficiency to handle extra heavy weight 16-ply denim. Engineered with extra feeding strength for seaming the inside of jeans.

# MS-3580 Se

## Feed-off-the-arm, 3-needle Double Chainstitch Machine

Smooth, efficient feeding of extra heavy weight 16-Ply, 14 oz denim for seaming inside seams.

### ◎ Strong feeding mechanism of the puller

The puller incorporates a one-way clutch mechanism which contributes to consistent feeding of the material.

(The mechanical part is protected by a cover for added safety.)

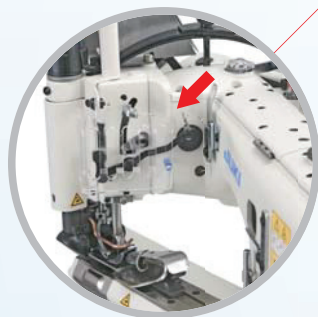
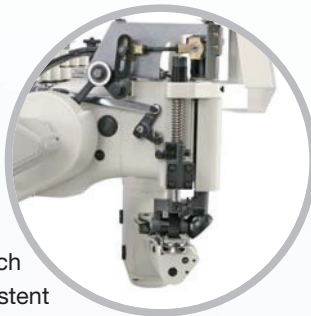

### ◎ Thread take-up device which helps produce even stitches with consistency

The feeding amount of needle thread is automatically adjusted to the pressure foot height during sewing, thereby producing even stitches with consistency.

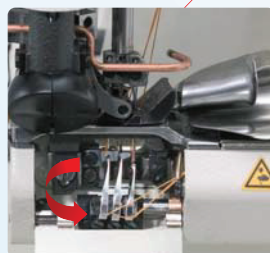

### ◎ The machine has been designed to achieve the best possible ease of threading.

When the looper pushbutton (\*) located on the operator side of the top of the machine head is pushed, the tip of the looper moves downward to allow the operator to thread the machine head with ease.

### ◎ The differential feed adjusting lever is located on the front face of the machine head.

The differential feed adjusting lever can be adjusted even during sewing, thereby effectively preventing cloth slippage between two plies.

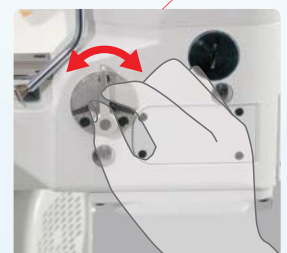

◎The machine type without the differential feed capability

The machine is best suited for lap seaming jeans, denim jackets, work uniforms, etc. constructed of heavy weight materials.



MS-3850SF0SN



The machine demonstrates increased efficiency of feed even when seaming a yoke part (16-layered) in hip seaming processes.



\*Looper pushbutton

MS-3580SF1SN



| SUBCLASS    |   |                   |  |                   |              |                                |                            |  |   |  |
|-------------|---|-------------------|--|-------------------|--------------|--------------------------------|----------------------------|--|---|--|
| Model No.   | Materials                                   | Number of needles | Needle gauge (mm)                                | Differential-feed |              | Top feed puller driving method | Top feed roller width (mm) | Roller configuration                             | Difference in height of the throat plate (mm) |  |
|             |   |                   |  | Provided          | Not provided |                                |                            |  |   |  |
| MS3580SF0SN | Medium- to heavy-weight materials (10~14oz) | 3                 | 6.4  |                   | ●            | Mechanical driving method      | 11.9                       | Steel teeth (standard)<br>Parts No.40068568      | 2.38  |  |
| MS3580SF1SN |   |                   |  |                   | ●            |                                |                            | Steel teeth (reverse teeth)<br>Parts No.40077682 |   |  |
| MS3580SF0RN |   |                   |  |                   | ●            |                                |                            | Steel teeth (standard)<br>Parts No.40068568      |   |  |
| MS3580SF1RN |   |                   |  |                   | ●            |                                |                            | Steel teeth (reverse teeth)<br>Parts No.40077682 |   |  |
| MS3580SG0SN |   |                   |  | 7.2               |              |                                |                            | ●  |   | Steel teeth (standard)<br>Parts No.40068568      |
| MS3580SG1SN |   |                   |  |                   |              |                                |                            | ●  |   | Steel teeth (reverse teeth)<br>Parts No.40077682 |
| MS3580SG0RN |   |                   |  |                   | ●            |                                |                            | Steel teeth (standard)<br>Parts No.40068568      |   |  |
| MS3580SG1RN |   | ●                 | Steel teeth (reverse teeth)<br>Parts No.40077682 |                   |              |                                |                            |  |   |  |

# SPECIFICATIONS

| Model name                      | MS-3580S*1SN   | MS-3580S*0SN                             |
|---------------------------------|--|--|
| Stitch type                     | 3-needle, 6-thread, double chainstitch machine                                   |  |
| Application                     | For medium- to heavy-weight materials: jeans, denim jackets, work uniforms, etc. |  |
| Max. sewing speed               | 4,500rpm   |  |
| Normal sewing speed             | 3,500rpm   |  |
| Needle gauge                    | 6.4mm, 7.2mm   |  |
| Stitch length                   | 2.1mm~3.6mm (standard 3.2mm)   |  |
| Needle (standard)               | UY130GS (standard) /Nm140 (#22)  |  |
| Needle bar stroke               | 33mm   |  |
| Number of pieces of thread used | 6  |  |
| Weight of the machine head      | 23.5kg   |  |
| Lift of the presser foot        | Max. 9mm (at the time of delivery 6.5mm)   |  |
| Top feed roller width           | 11.9mm   |  |
| Feed adjusting method           | Main feed: Slide-type stitch-length adjusting method                             |  |
|                                 | Differential feed: Lever adjusting method  | Without the differential feed capability |
| Lubrication                     | Automatic rotary-pump type oiling  |  |
| Lubricating oil                 | JUKI MACHINE OIL No. 18  |  |
| Installation method             | To be installed on the table by means of an auxiliary drive assembly MT03        |  |

## WHEN YOU PLACE ORDERS

Please note when placing orders, that the model name should be written as follows:

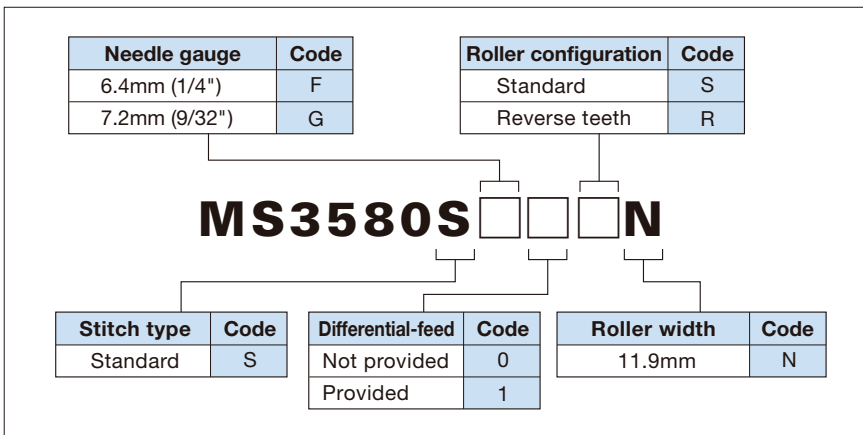

● To order, please contact your nearest JUKI distributor.

### ● Folder assembly

Various folder assemblies are available according to the properties and weight of the material to be used.

| Description    | Parts No. | Outlet dimension | Application                                  |
|----------------|-----------|------------------|--|
| 3/32" folder   | 40072322  | 2.4mm            | Medium-weight materials                      |
| 18-1/8" folder | 40066942  | 3.2mm            | Medium- to heavy-weight materials (standard) |
| 5/32" folder   | 40072324  | 4.0mm            | Extra heavy-weight materials                 |
| 9-1/8" folder* | 40072328  | 3.2mm            | Medium- to heavy-weight materials            |

\*Since the top of the folder is shorter than the standard one, the material can be handled with ease.

## OPTIONS

### ● Auxiliary drive assembly MT03



★ To install the machine on the table, the auxiliary drive MT03 is required.

### ● Table stand JTMS5

Table stand for the MS-3580 (without casters)



★ This table stand is specifically designed for the SC-510. The M-51 motor should be used.

**JUKI**<sup>®</sup>  
JUKI CORPORATION  
MARKETING & SALES H.Q.

8-2-1, KOKURYO-CHO, CHOFU-SHI,  
TOKYO 182-8655, JAPAN  
PHONE : (81) 3-3480-2357, 2358  
FAX : (81) 3-3430-4909  
http://www.juki.com

\* Specifications and appearance are subject to change without prior notice for improvement.  
\* Read the instruction manual before putting the machine into service to ensure safety.  
\* This catalogue prints with environment-friendly soyink on recycle paper.



**JUKI CORPORATION HEAD OFFICE**  
Juki Corporation operates an environmental management system to promote and conduct the following as the company engages in the research, development, design, sales, distribution, and maintenance of industrial sewing machines, household sewing machines, industrial robots, etc., and in the provision of sales and maintenance services for data entry systems:  
① The development of products and engineering processes that are safe to the environment  
② Green procurement and green purchasing  
③ Energy conservation (reduction in carbon-dioxide emissions)  
④ Resource saving (reduction of papers purchased, etc.)  
⑤ Reduction and recycling of waste  
⑥ Improvement of logistics efficiency (modal shift and improvement of packaging, packing, etc.)